

Arch Environmental Equipment, Inc. “RGS” METAL BLADE SECONDARY BELT CLEANER (rev:2)

INSTALLATION INSTRUCTIONS

THE TOOLS & RESOURCES REQUIRED ARE:

- | | |
|------------------|----------------------|
| 1. TAPE MEASURE | 5. ADJUSTABLE WRENCH |
| 2. STRAIGHT EDGE | 6. WELDING EQUIPMENT |
| 3. CUTTING TORCH | 7. CHALK |
| 4. LEVEL | |

THE SECONDARY CLEANER SHOULD BE MOUNTED WITHIN THREE INCHES OF THE POINT WHERE THE BELT LEAVES THE HEAD PULLEY. THE CLEANER MAY BE MOUNTED FARTHER AWAY, BUT SHOULD HAVE SOME KIND OF A ROLLER SURFACE INSTALLED ABOVE IT ON THE CLEAN SIDE OF THE BELT

SHUT DOWN AND LOCKOUT CONVEYOR BEFORE PERFORMING ANY MAINTENANCE

STEP 1

The centerline of the tensioner pipe (item 2 – fig. 2) should be mounted below the belt about 2 ½” (63.5mm) for a “RGS”, see dim. “A” – fig. 1. You may have to fabricate the structure in order to do this. You will need a surface of at least 4 ½” (114.3mm) wide to accommodate the tensioner (item 3 – fig. 2) and weld hub (item 6 – fig. 2). You will need to cut or burn a 2 ½” (63.5mm) hole for the tensioner pipe to pass through with its center line below the belt surface as referred to in dim “A”-fig 1. Make sure that hanger brackets are perpendicular to the belt. When locating the cleaner ensure the metal blade tip is beyond the point where the belt leaves the pulley (see dimension B). Generally a distance of 3” (76.2mm) is a safe measurement.

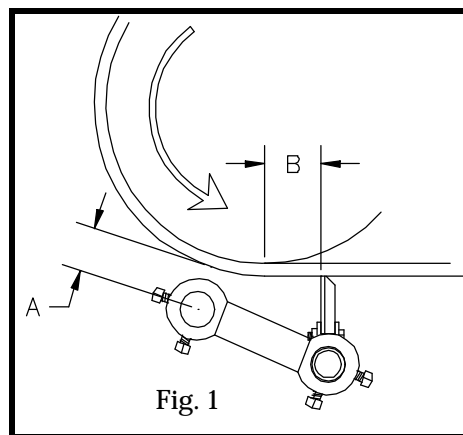

STEP 2

Now, remove the tensioner and weld hub (or second tensioner if supplied with your cleaner) from the cleaner and slide the tensioner pipe from the pivot arms (item 7 – fig. 2). You may leave the arms attached to the cleaner mainframe.

STEP 3

Now you can slide the tensioner pipe through the brackets. As you run the tensioner pipe through the first bracket, you will need to slide back through the pivot arms at the same time (see fig. 2). Do not tighten the setscrew in the pivot arms yet, let them hang freely on the tensioner pipe. Now, slide the tensioner over the end of the pipe that has the slots in it and insert the tensioner pin (item 4 –fig. 2). After placing the weld hub (item 6 – fig. 2) on the opposite end (or second tensioner), hold the pipe so the centerline is at 2 ½” (63.5mm) (Dim A - fig. 3) from the face of the belt. Tack-weld the tensioner and weld hub to the mounting brackets. (note: if your cleaner is equipped with dual tensioners then item 6 will be omitted and replaced with a second item 3). Note: Cleaners over 48” may be supplied with dual tensioners. This will require the installer to locate additional holes in the tensioner pipe to accommodate the placement of the tensioner pin through the index hub and pipe. These holes will be located on the opposing side of the pipe where the factory-installed slots are found.

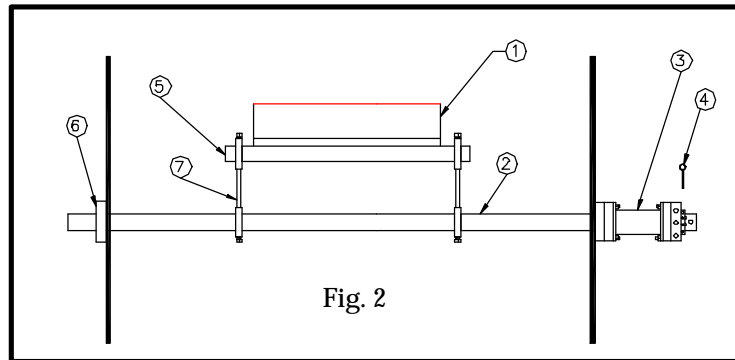

Fig. 2

STEP 4

Swing the cleaner frame up until it contacts the belt. Make sure that the blade contacts the belt evenly and is mounted parallel with the face of the belt. Tighten the setscrews in the pivot arms on the tensioner pipe. After this has been done, you may complete the welding on the hubs. Three (3) one inch (1”) welds spaced around the hubs are all that is needed.

STEP 5

Remove the tensioner pin(s) and verify that the cleaner rotates freely in the hubs. If needed, make any adjustments that are necessary.

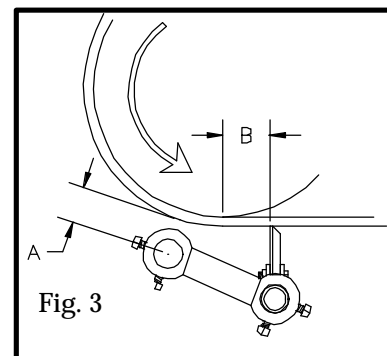

Fig. 3

STEP 6

You are now ready to tension the cleaner. Holding the blade against the belt, place the wrench into the outer hub and rotate it in the direction of belt travel, approximately two (2) holes (see fig. 4), and reinsert the tensioner pin. **That's it!**

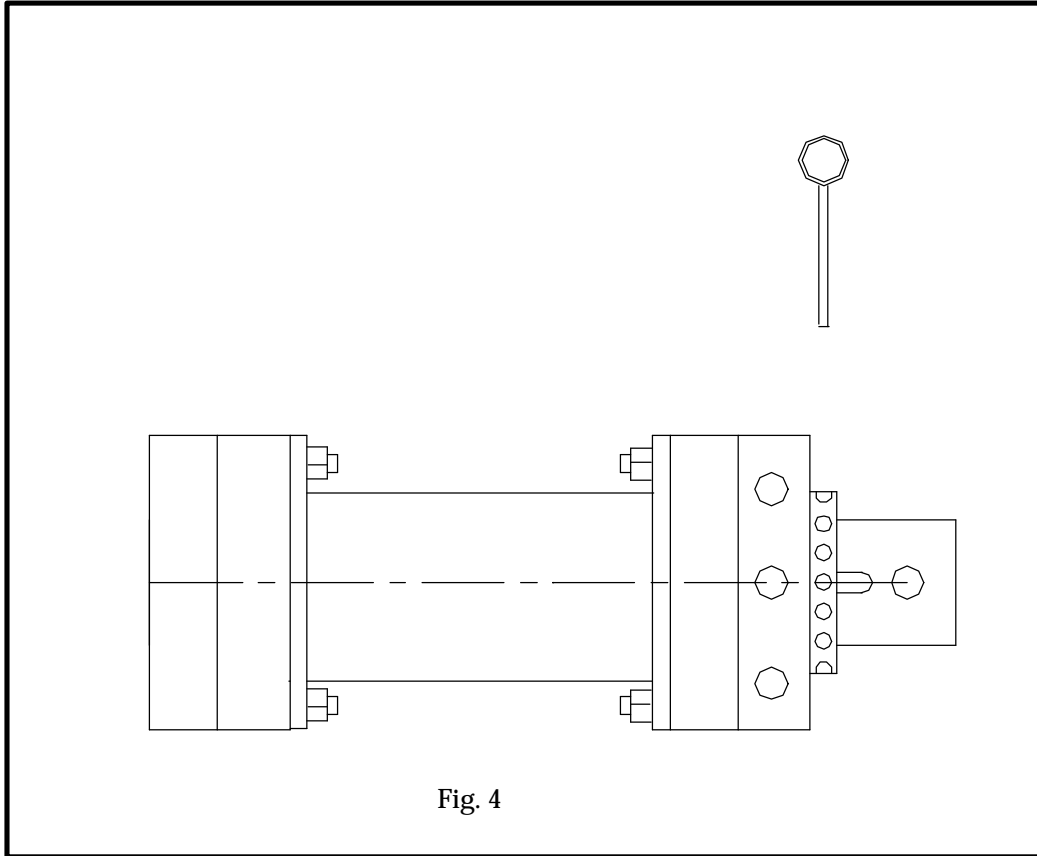

Fig. 4