

Arch Environmental Equipment, Inc. ARCH METAL-BLADED SECONDARY CLEANER

INSTALLATION INSTRUCTIONS

THE TOOLS & RESOURCES REQUIRED ARE:

- | | |
|------------------|----------------------------|
| 1. TAPE MEASURE | 5. ADJUSTABLE WRENCH |
| 2. SQUARE | 6. WELDING EQUIPMENT |
| 3. CUTTING TORCH | 7. CHALK |
| 4. LEVEL | 8. 4 – 5/8" MOUNTING BOLTS |

***SHUT DOWN AND LOCKOUT CONVEYOR BEFORE
PERFORMING ANY MAINTENANCE***

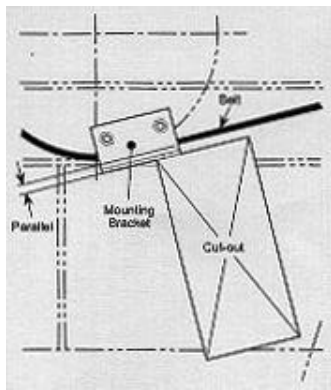

Fig 1

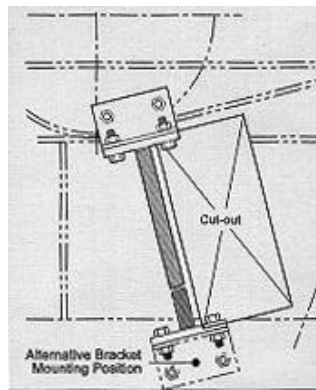

Fig 2

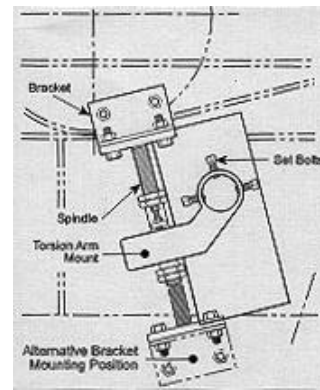

Fig 3

Step 1

Prepare cutouts (7"[178mm] x15"[381mm]) on both sides of chute, and install brackets on both sides of chute parallel to the conveyor belt line. (figure 1)

Step 2

Attach the spindle to the prepared bracket (supplied by installer – if required) on one side of the conveyor. Bolt spindle to bracket one side only. (figure 2)

Step 3

Attach one of the spindles and one of the Torsion Mounts to make an assembly. (figure 3)

Note: At this stage the position of the Torsion Mount on the spindle should be:

- If the spindle is to be installed in a "hanging position" "1-1/4" of thread showing from the end of the spindle.
- If the spindle is to be installed in a "standing position" "1-1/4" of thread showing from the foot of the spindle.

Bolt this assembly onto the conveyor structure with two 5/8" bolts. (not included)

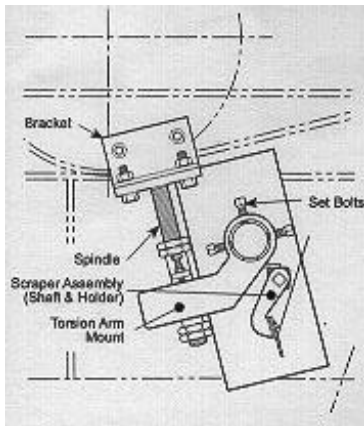

Fig 4

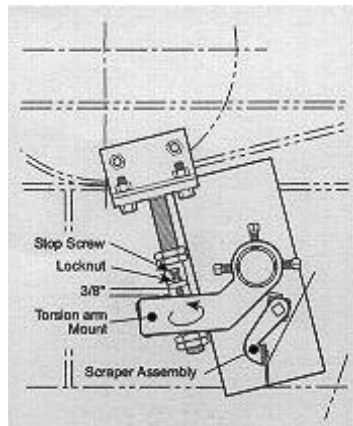

Fig 5

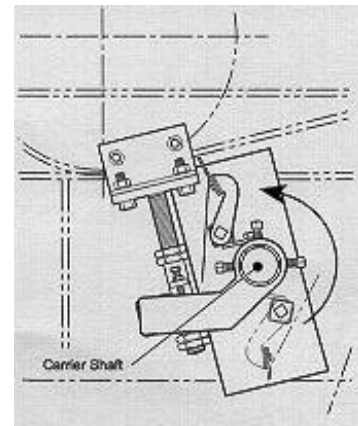

Fig 6

Step 4

Insert the Carrier Shaft into the Torsion Mount/Spindle assembly bolted to the conveyor structure. Attach the other Torsion Mount and Spindle to make a second assembly. Then, slide the second assembly onto the end of the Carrier Shaft and lift the Scraper Unit (which now includes the second Torsion Mount/Spindle assembly) and bolt to the conveyor structure with two 5/8" bolts (not included). *Note: Once this instruction is completed the Carrier Shaft, with Blades/Torsion holders will be in a hanging position.* (figure 4)

Step 5

To preload the torsion mount, adjust the Stop Screw until it touches the Torsion Mount Arm. Continue to adjust the Stop Screw up to 3/8". *Note: The Torsion Mount is now preloaded.* (figure 5)

Step 6

Rotate the Carrier Shaft 180° so that the blades/holders are in a vertical position. *Note: If you have followed the instructions correctly, the tips of the blades will just below the belt surface.* (figure 6)

Centralize the Carrier Shaft to the belt width. Set the Carrier Shaft parallel to the belt line. Check that the Torsion Mount/Carrier Shaft is horizontal on the spindles. Now lightly tighten the three set bolts in each of the Torsion Mounts, but only sufficiently to ensure that the Carrier Shaft does not tip over. *Note: Please do not over tighten the set bolts at this stage as the final setting of the Carrier Shaft does not tip over.* (figure 7)

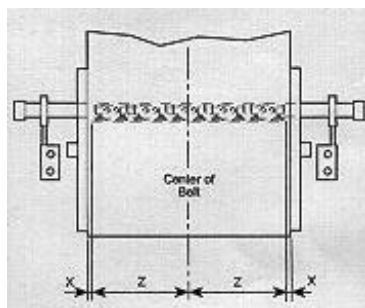

Fig 7

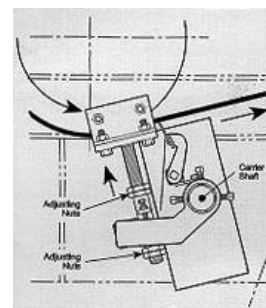

Fig 8

Step 7

Raise the Carrier Shaft until the blades lightly touch the belt. *Note: Adjusting the top and bottom nuts on the spindle, allows the Carrier Shaft to be moved vertically up or down.* (figure 8)

Step 8

To establish that the Carrier Shaft is parallel with the belt line, use an Engineers Square to check that the 3/8"x1 1/4" flat on top of the Carrier Shaft is parallel with the belt. If not, loosen the three set bolts in each of the Torsion Mounts to enable the shaft to rotate. After establishing that the Carrier Shaft is parallel with the belt line, ensure that the three set bolts in each of the Torsion Mounts are firmly tight. Finally, turn the Stop Screw counter-clockwise to create a gap of 3/8" from the Torsion Arm. (figure 9)
The scraper is now set and ready for operation.

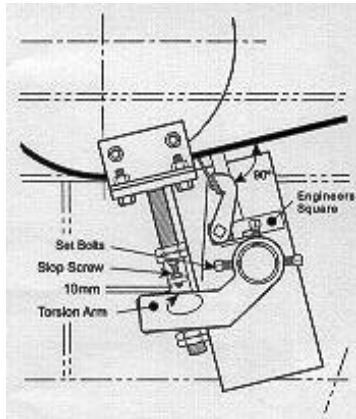

Fig 9

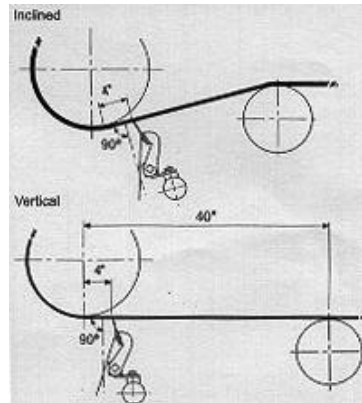

Fig 10

Recommended Blade Position

Checklist:

- 1) Spindles are installed at 90° to the belt surface.
- 2) The Scraper Unit is parallel to the belt.
- 3) a. Inclined - The recommended blade position is 4" minimum from the nip point (tangential point) where the belt leaves the head drum, in the cases where snub pulleys are installed.
b. Vertical - The recommended blade position is 4" minimum from the vertical centerline of the head drum.
- 4) In Installations where there is no snub drum, the first return roller should be installed approximately 40" from the center of the head drum. This will ensure that the belt is sufficiently supported. (figure 10)

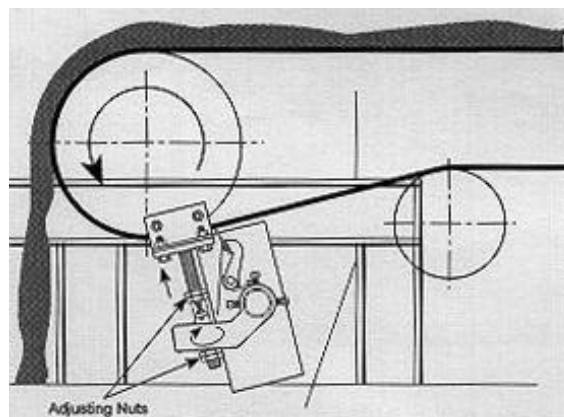

Fig 11

Start-up of the Belt

- 1) Unlock the conveyor.
- 2) Perform a test run with material on the belt.
 - a. Check the belt tracking.
 - b. Installation is complete.

Note: If cleaning efficiency is not being achieved adjust spindle nuts to raise the shaft assembly until correct cleaning efficiency is achieved. (figure 11)

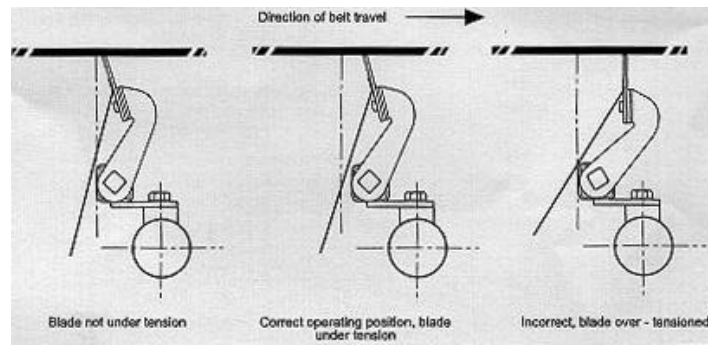

Fig 12

Blade Setting

In order to ensure that the Arch Metal-Bladed Segmented Secondary Scraper operates correctly, it is essential that all blades are inclined in the direction of the belt traveling using the belt scraper principle like a “paint scraper”. (figure 12)

If you should have any questions or comments, please contact Arch Environmental Equipment at (800) 553-4567 or fax us at (800) 230-9462.

Thank you for using Arch Environmental Equipment products!



P.O. Box 1760 5929 Benton Road Paducah, KY 42002-1760
1-800-553-4567 / 270-898-6821 Fax: 1-800-230-9462 / 270-898-8061
<http://www.aeec.com>