

Arch Environmental Equipment, Inc. GORDON SABER “DUAL” PRIMARY BELT CLEANER

INSTALLATION INSTRUCTIONS

THE TOOLS & RESOURCES REQUIRED ARE:

- | | |
|------------------|-------------------------|
| 1. TAPE MEASURE | 5. WELDING EQUIPMENT |
| 2. STRAIGHT EDGE | 6. STRING (36" or more) |
| 3. CUTTING TORCH | 7. CHALK |
| 4. LEVEL | |

***SHUT DOWN AND LOCKOUT CONVEYOR BEFORE
PERFORMING ANY MAINTENANCE***

STEP 1

Determine the diameter of the head pulley and the thickness of the conveyor belt. Example: head pulley diameter = 24" (609.6mm), belt thickness = $\frac{3}{4}$ " (19.05mm). Take one half of the head pulley measurement (in this case 12" (304.8mm)) and add the belt thickness. This will give an effective radius of 12 $\frac{3}{4}$ " (323.85mm).

STEP 2

To this number add dimension "A" (either 2 $\frac{3}{4}$ " (69.85mm) or 3 $\frac{1}{2}$ " (88.9mm)). This will give you the "Z" dimension. See fig. 1. To determine dimension "A" (spacing from the face of the belt), you must first determine the head pulley diameter. If the pulley diameter is 22" or smaller, then an "A" dimension of 3 $\frac{1}{2}$ " (88.9mm) should be used. If the head pulley diameter is larger than 22", use an "A" dimension of 2 $\frac{3}{4}$ ". To assist you in achieving this spacing, urethane "installation rings" have been included with the cleaner, Use these as directed below in step 8.

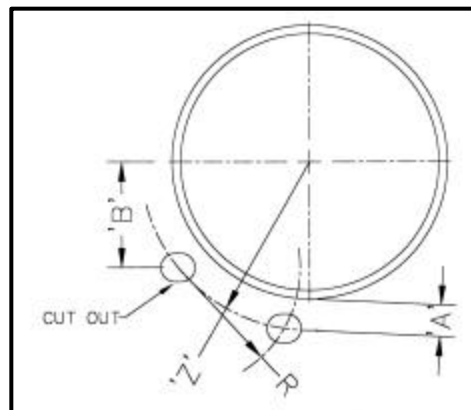

Fig. 1

STEP 3

Using the “Z” dimension as described in step 2., use the string and chalk to draw an arc (with radius of “Z”) to define the area for cutting the mounting holes on the chute wall.

STEP 4

From the centerline of the head pulley measure down 9 ½” (241.3mm) (FIG. 1, Dimension “B”). This is the highest point that the upper cleaner should be mounted. It can be mounted anywhere along the radius that was marked off in step 3. The limiting factor is the restriction of a dribble chute or lack of a dribble chute at the point where the belt leaves the head pulley on the return side. **Note: DO NOT install the cleaner within the material trajectory.**

STEP 5

To locate the hole for the lower cleaner, you will need to use the string and chalk to draw another radius. The center point of the radius will be the center of the slot you just completed. From this center, draw an arc with a minimum radius (Dimension “R” - FIG. 1) of 10” (254mm). At the point where the “R” and “Z” radius intersect, you will need to draw your second hole as described in step 6. **Note: If the intersection of radii is beyond the point where the belt leaves the pulley, you will need to either relocate the upper mounting holes higher on the “Z” radius or decide if the dual primaries will fit on the pulley. A different model belt cleaner may be required, please consult the factory if you have any questions.**

STEP 6

After you have located the correct position to mount the cleaner, Mark two holes (per side) approximately 2 ½” (63.5mm) x 3” (76.2mm) in size. These should now be torched or cut out. (reference FIG. 1)

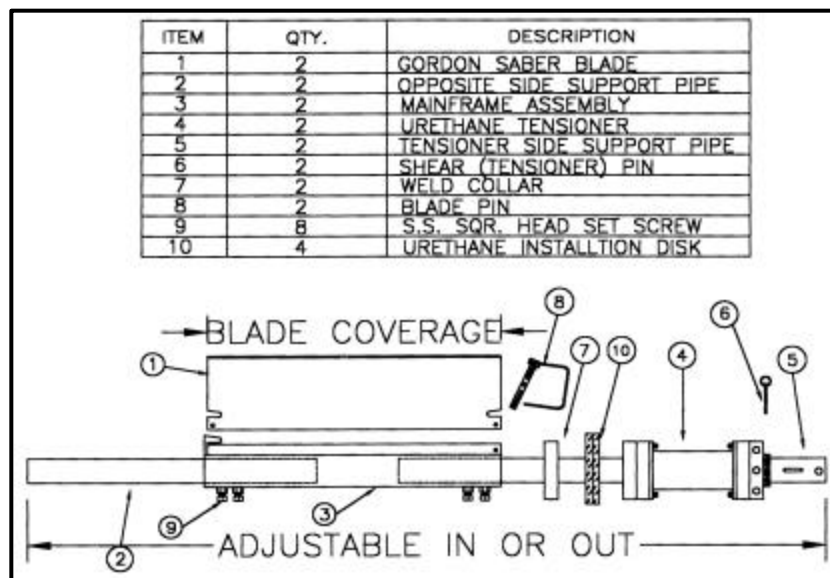

STEP 7

Disassemble both cleaners, one at a time (FIG. 2). This is done by removing the pin (ITEM 6) at the end of the index hub. Remove the tensioner (ITEM 4 - FIG. 2) from the tensioner pipe. You will notice when the tensioner is removed, there is another weld collar (ITEM 7 - FIG. 2). This is the weld collar for the opposite side. You should also notice two urethane rings (ITEM 10 - FIG. 2) and installation instructions included in the packaging. These rings are used to verify the "Z" and "A" dimensions. You will also find the tensioner wrench inside the tensioner pipe. Loosen the setscrews (ITEM 9 - FIG. 2) on the mainframe. *Caution! Loosen them only enough to allow both pipes (ITEMS 2 & 5 - FIG. 2) to be removed from the cleaner mainframe (ITEM 3 - FIG. 2).*

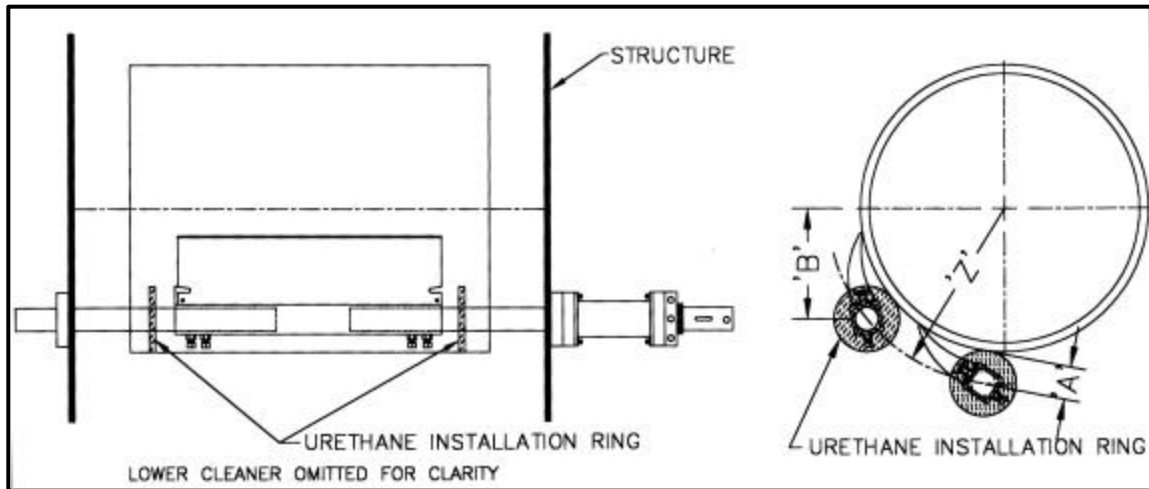

Fig. 3

STEP 8

Put the frame and blade assembly (ITEMS 1 & 3 - FIG. 2) inside the chute, and slide the support pipes (ITEMS 2 & 5 - FIG. 2) through the 2 ½" (63.5mm) x 3" (76.2mm) holes previously cut. Then slide the weld collar (ITEM 7 - FIG. 7) and the tensioner (ITEM 4 - FIG. 2) onto the support & tensioner pipes. Next, level the cleaner in relation to the head pulley. Verify the "Z" dimension by slipping the installation rings onto the support & tensioner pipe (see FIG 3). **If the head pulley diameter is larger than 22", remove the outer ring.** The installation ring should be placed against the belt. Tack weld the weld collar and tensioner into place. Set the cleaner blade against the belt and insert the pin (ITEM 6 - FIG. 2) into the tensioner hub. Tighten the setscrews on the mainframe. Pull the pin again to check if the cleaner rotates freely in the hubs; if it doesn't, realign the hubs until it rotates freely. (repeat step 8). Now, complete welding on the hubs (3-1" (25.1mm) welds on each hub is enough).

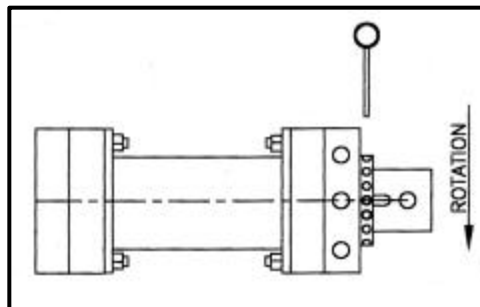

Fig. 4

STEP 9

Finally, pull the pin (ITEM 6 - FIG. 2) and rotate the tensioner away from the head pulley, until the next hole shows (SEE FIG. 4) in the tensioner hub. Reinstall the pin.
Repeat step 9 for lower cleaner.

If there are any questions or comments, please contact Arch Environmental Equipment at (800) 553-4567; fax (800) 230-9462, or e-mail arch@aeec.com.

Thank you for using Arch Environmental Equipment products!



P.O. Box 1760 5929 Benton Road Paducah, KY 42002-1760
1-800-553-4567 / 270-898-6821 Fax: 1-800-230-9462 / 270-898-8061
<http://www.aeec.com>

Gordon Belt Cleaning Systems • Tri-Return Training Idler • Wyatt Alignment Disks • Simplicity Access Doors • Gordon "At-Last-A-Seal" Skirt Rubber Flexiskirt Sealing System • Gordon Dust Seal • Simplicity Slider System • Dust Shark Dust Suppression System • Simplicity Chute Liner • Fogger System
Simplicity Impact System • Conveyor Controls & Belt Protection Equipment • ArchWeigh Belt Scales • Metasearch Metal Detector